

# CoroMill® MS60

True versatility in  
shoulder and face  
milling operations





# Experience true versatility

Discover the unparalleled versatility of shoulder milling solution  
CoroMill® MS60.

This dependable and cost-effective concept is specifically  
engineered for 90° shoulder milling but excels in a wide range of  
applications.

From face milling to ramping, pocketing, and modern dynamic  
milling, it's a tool that adapts to your diverse machining needs  
with exceptional ease.

# Exceptional efficiency at a low cost

Elevate your productivity and lower your cost per part with CoroMill® MS60. Featuring 6 indexing options, this tool offers a cost-effective solution, ensuring exceptional efficiency across various milling operations.

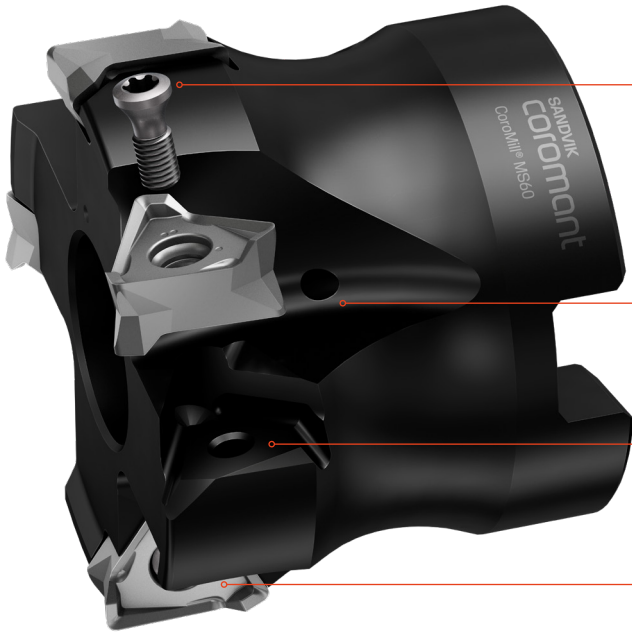

10IP TORX PLUS® screw to ensure 2 Nm (17.7 in-lb) tightening torque

Internal coolant for better chip evacuation – especially for NCI machining

Robust tip seat design provides additional security against variable forces due to casting and forging variations

Triangular double-sided insert for optimum insert fit

## Six-edged magnificence

Thanks to its unique six-edged and direct-pressed inserts, CoroMill® MS60 can effectively handle roughing to semi-finishing operations in steel and cast iron.

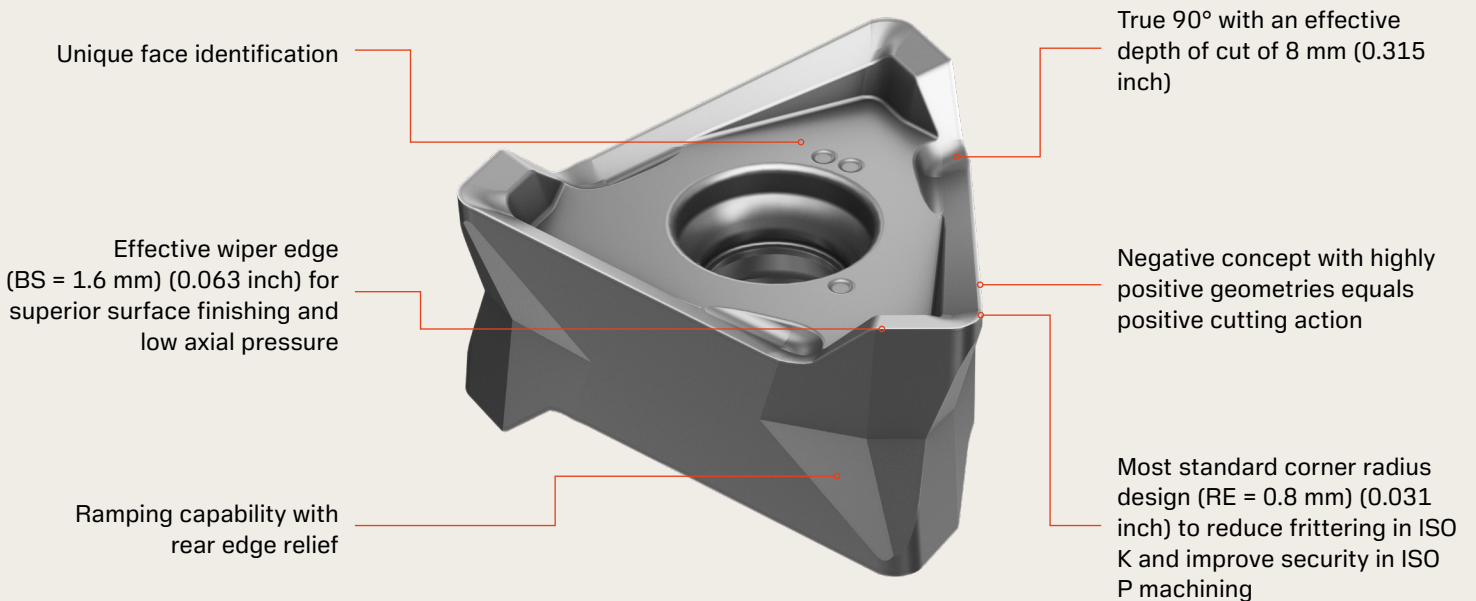

Unique face identification

True 90° with an effective depth of cut of 8 mm (0.315 inch)

Effective wiper edge (BS = 1.6 mm) (0.063 inch) for superior surface finishing and low axial pressure

Negative concept with highly positive geometries equals positive cutting action

Ramping capability with rear edge relief

Most standard corner radius design (RE = 0.8 mm) (0.031 inch) to reduce chattering in ISO K and improve security in ISO P machining

# Application

## Application areas:

- Roughing and semi-finishing face and shoulder milling applications where traditionally a multi-edge or tangential milling solution is used
- True 90° shoulder milling operations
- Ramping operations
- Main application areas: ISO P and ISO K
- Secondary application areas: ISO M and ISO S

## For general engineering of components such as:

- Housing/casing, pump and valve parts, machine bed, machine table, head stock



# Assortment

Cutter body Ø		Pitch	Coupling type	Internal coolant
Metric	50–100 mm	M - differential	Arbor	Yes
Metric	50–100 mm	H - differential	Arbor	Yes
Inch	2.00–4.00	M - differential	Arbor	Yes
Inch	2.00, 3.00, 4.00	H - differential	Arbor	Yes

Insert size	Insert geometry	Grade
16 (IC9.6)	M-L50	GC1130, GC4330, GC1020, GC3330, GC1040
16 (IC9.6)	M-M40	GC1130, GC4330, GC1020, GC3330

Learn more about CoroMill® MS60:  
[sandvik.coromant.com/coromillms60](https://sandvik.coromant.com/coromillms60)



Authorized distributor



1-800-923-6255  
[www.dgisupply.com](http://www.dgisupply.com)

